

Homework 2

Problem 1. Consider the system shown in Figure 1. The system is at rest for $t < 0$. Assume that the displacement x is the output of the system and is measured from the equilibrium position. At $t = 0$, the cart is given initial conditions $x(0) = x_0$ and $\dot{x}(0) = v_0$.

- (1) Derive the equations of motion for the system shown in Figure 1.
- (2) Assume that $m = 10$ kg, $b_1 = 50$ N·s/m, $b_2 = 70$ N·s/m, $k_1 = 400$ N/m, and $k_2 = 600$ N/m. Obtain the output motion $x(t)$.

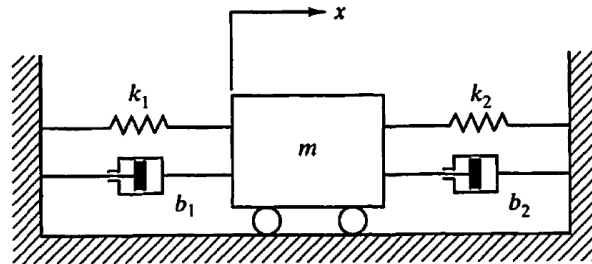

Figure 1: Mechanical system

Problem 2. Consider the system shown in Figure 2.

- (1) Derive the equations of motion.
- (2) Obtain the transfer functions $X_1(s)/U(s)$ and $X_2(s)/U(s)$.

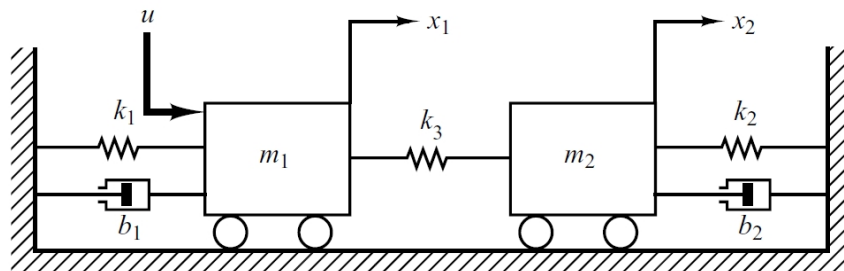

Figure 2: Mechanical system

Problem 3. Consider the system shown in Figure 3. The torque $\tau_a(t), t \geq 0$, is applied to the disk J_1 .

- (1) Determine the number of degrees of freedom for the system.
- (2) Obtain the equations of motion.
- (3) Obtain the transfer function $\Theta_3(s)/T_a(s)$.

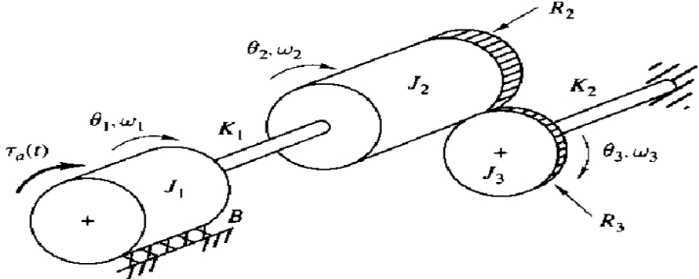

Figure 3: Mechanical system

Problem 4. Simplify the block diagram and obtain the transfer function $C(s)/R(s)$.

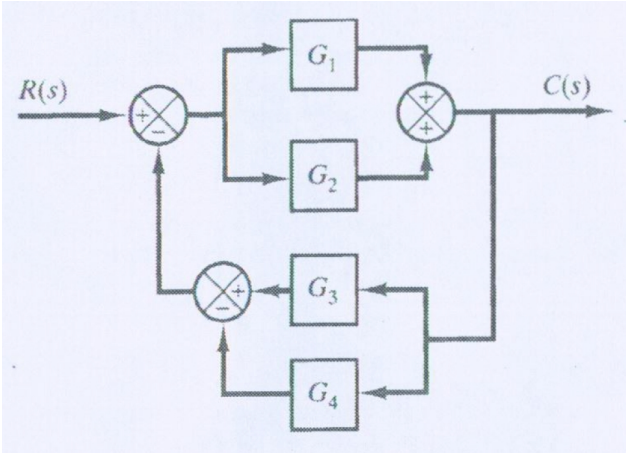

Figure 4: Block diagram

Problem 5. Simplify the block diagram and obtain the transfer function $C(s)/R(s)$.

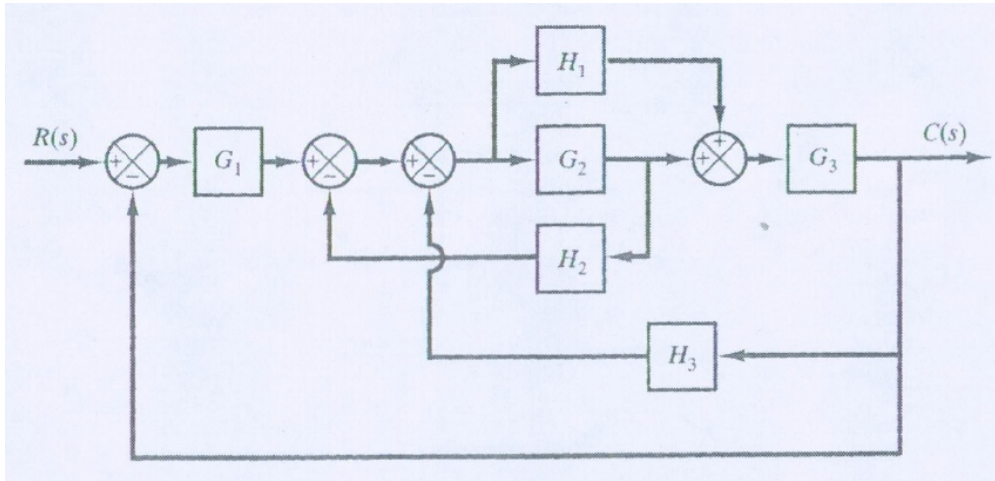

Figure 5: Block diagram

Problem 6. Find the transfer function $Y_1(s)/R_2(s)$ for the system in Figure.

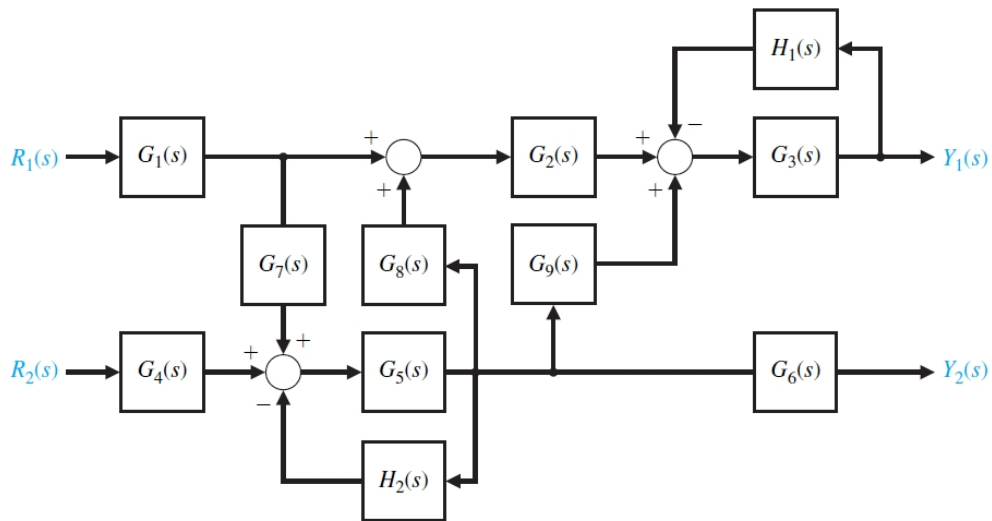

Figure 6: Block diagram